

**PHILIPS**

*VideoTracer*

音视频记录仪

VTR8300

使用手册

User manual





# 目录

---

1	欢迎	5	6	拍照	13
1.1	产品特点	5	7	录音	14
2	重要须知	6	8	一键回放模式	15
2.1	安全	6	9	视频模式	16
2.2	听力保护	6	9.1	视频播放	16
2.3	录音的法律限制	6	10	照片模式	18
2.4	天线装配	6	11	语音模式	19
3	您的音视频记录仪	8	11.1	语音播放	19
3.1	供货范围:	8	12	对讲机	20
3.2	主机概览:	8	12.1	对讲机功能开关	20
4	开始使用	10	12.2	对讲机设置	20
4.1	开 / 关机	10	12.3	对讲音量调节	20
4.2	充电方法	10			
4.3	连接电脑	11			
5	录像	12			

---

13	设置模式	21	17.2	尺寸和重量	33
13.1	对讲机设置	21	17.3	系统要求	33
13.2	录音设置	22	17.4	录音	33
13.3	录像设置	23	17.5	运行条件	33
13.4	拍照设置	24			
13.5	系统设置	25			

---

14	背夹的装取	30			
----	-------	----	--	--	--

---

15	背夹的佩戴方法	31			
----	---------	----	--	--	--

---

16	常见问题	32			
16.1	无法启动音视频记录仪	32			
16.2	显示时间 / 日期不正确	32			
16.3	拍照 / 录像图像模糊, 不清楚	32			
16.4	音视频记录仪无法录音或者录像	32			
16.5	音视频记录仪无法播放录音或者录像	32			
16.6	音视频记录仪死机后如何处理	32			

---

17	技术参数	33			
17.1	存储器	33			

# 1 欢迎

欢迎来到飞利浦世界！您能选择和购买飞利浦的产品，我们非常高兴。您可在我们的官方网站上获得飞利浦公司的全方位技术支持，如：使用手册、软件下载、保修信息等。

[www.philips.com](http://www.philips.com)

## 1.1 产品特点

- 一键录音：仅仅按下录音键即可实现录音，再按一下录音键保存录音。
- 一键录像：仅仅按下录像键即可实现录像，再按一下录像键保存录像。
- 一键回放功能：录音或者录像后，按右键，直接进入文件播放。
- 专业音频编解码器，实现高品质录音。
- 独立对讲机功能，真正实现音视频记录仪和对讲机二合一。
- 145° 超大广角镜头，录像无死角。
- 双滤光片切换器，白天不偏色，夜晚更清晰。
- 3.5mm 标准耳机，在嘈杂的环境下回放声音更清晰。
- 字符叠加功能，所有视频和照片都附加时间、产品编号、使用者编号等信息，无法剪辑，更具法定证据效力。
- 超长文件名，所有录像文件的文件名都包含产品编号、时间、

使用者编号等信息，方便数据存档、检索。

- 录像资料自动分割保存，防止误操作造成资料丢失。
- VTR8300 为外置存储卡，最大支持 128G。
- 高清扬声器：采用高品质振动喇叭，无论播放录音文件或录像文件，都给人身临其境的享受。
- 以常见的 WAV 格式录音。
- 使用高速 USB 2.0 快速存取录音文件和数据。
- 可作为大容量的 USB 存储设备，确保最大的兼容性。

## 2 重要须知

---

### 2.1 安全



#### 注意

- 此符号标志指明处理或操作设备时必须遵守的各种注意事项。



#### 小心

特别声明：使用本产品前请仔细阅读本说明书，如因人为操作或不可抗力因素而导致数据丢失，本公司一概不予负责。特别提醒用户小心操作，注意将资料另外备份。

### 2.2 听力保护

使用耳机时请遵守下列原则：

- 调整至合适的音量，切勿长时间使用耳机。
- 特别需要注意，切勿将音量调至耳朵所能承受的范围之外。
- 切勿将音量调至盖过周边环境的声音。
- 在危险情况下请小心或暂停使用耳机。

- 在驾驶汽车、骑自行车、玩滑板时，切勿使用耳机。否则会导致交通意外，且违反相关法律法规。

### 2.3 录音的法律限制

- 本设备录音功能的使用可能受限于所在国家法律的限制。录制他人谈话或者课程时应尊重他人隐私及第三方人权。
- 请注意，在部分国家，当录制用户与他人通话时，用户应根据法律要求通知对方，否则该录音行为将被视为不合法。请在电话录音前确认使用者所在国家该录音数据使用的合法性。

### 2.4 天线装配

为了方便包装以及运输，音频记录仪的对讲天线是拆开包装，客户需要把天线装回去才能使用对讲，具体操作如下：

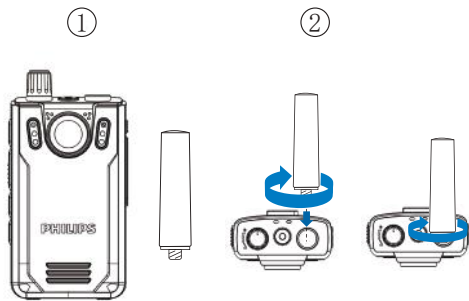

### 注意

- 天线扭紧不松动即可，不需要一直在扭，避免损坏。
- 不要往一边掰动天线，避免折断影响信号。

### 3 您的音视频记录仪

#### 3.1 供货范围：

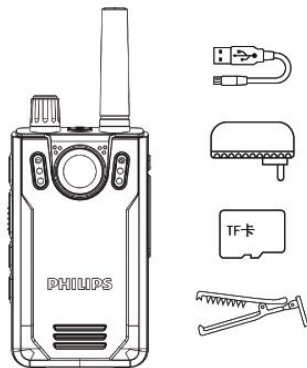

#### 3.2 主机概览：

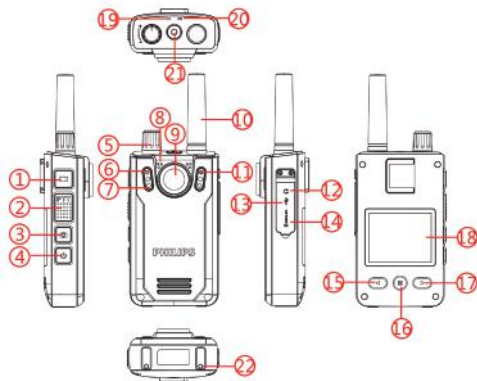



- ① 录像键
- ② PPT对讲键
- ③ 拍照键
- ④ 开机/关机键
- ⑤ 对讲机开关/对讲音量调节键
- ⑥ 光敏电阻
- ⑦ 红外灯
- ⑧ 麦克风
- ⑨ 摄像头
- ⑩ 对讲机天线
- ⑪ 白光灯
- ⑫ 耳机插口
- ⑬ USB接口
- ⑭ TF卡插口
- ⑮ 上一曲/快退/缩小/菜单选择键
- ⑯ 菜单/确定/播放/暂停/返回键
- ⑰ 下一曲/快进/放大/菜单选择键
- ⑱ 显示屏
- ⑲ 音视频记录仪状态指示灯
- ⑳ 对讲机状态指示灯
- ㉑ 录音键
- ㉒ 座充充电触点

## 4 开始使用

### 4.1 开 / 关机

#### 注意

- 第一次使用机器时，请对该机器在关机状态下充电 3 小时以确保机器有电工作！

关机状态下，长按开机键 3s，本机立即自动开机，然后显示飞利浦图标，如下图所示：



然后机器进入预览界面，如下图所示，预览状态下，工作状态指示灯亮绿灯，在此界面短按“≡”键，机器回到设置界面。在预览界面长按“◀”或“▶”键可放大与缩小，实现数码变焦功能。



#### 提示

- 本机使用内置锂电池供电，如果长时间不使用音视频记录仪，请长按开关机键 3s 关掉机器。
- 如果音视频记录仪无法正常工作，请确认机器是否已没电。
- 机器工作过程中，请勿直接把外置卡拔出，否则会损坏文件或导致机器异常。
- 当电量指示标志为“”时，请及时充电。

### 4.2 充电方法

- 关机状态下使用 USB 数据线将本机和出厂配备的充电器进行充电，充电过程中充电指示灯亮绿色灯，充满后熄灭。
- 如果是开机状态下使用 USB 数据线将本机和出厂配备的充电器进行充电，充电过程中显示屏上的电池格数在走动，

充满后电池符号满格不再走动。



#### 提示

- 本机充电可以使用关机充电和开机充电的方式，一般情况下，关机充满电需要 3 小时左右，开机充满电需要 5 小时左右（建议关机充电）。

### 4.3 连接电脑

音视频记录仪可作为大容量的 USB 存储设备，并可方便地与电脑相连，VTR8300 无须安装软件，音视频记录仪会自动显示为可移动设备。连接电脑图标如下图所示。



#### 提示

- 在文件移入或移出机器时，请不要断开机器与电脑的连接。
- 请将机器开机后再使用 USB 数据线将音视频记录仪与电脑相连或者使用 USB 数据线将音视频记录仪与电脑相连后长按电源键 3s。
- 如需要格式化 TF 卡，如果卡容量是 16GB-64GB，文件系统选项须选择 FAT32 进行格式化。如果卡容量是 128GB，则文件系统选项必须选择 exFAT 进行格式化。不能使用 NTFS 格式，否则机器将无法摄录。

## 5 录像

当您初次使用音视频记录仪录像时，请注意本节中的内容说明！

- (1) 在摄像预览状态按下“录像”键开始录像，状态指示灯将红灯闪烁。
- (2) 长按“◀”或“▶”键缩小与放大预览界面，实现数码变焦功能。
- (3) 在黑夜或者光线暗的环境下录像时，如果红外切换设置为手动，可长按“录音”键打开红外，此时红外灯开启进入到夜视拍摄模式，画面颜色为黑白模式。
- (4) 在黑夜或者光线暗的环境下录像时，长按“录像”键，照明灯将打开，补充光源。
- (5) 按“拍照”键可以抓拍当前拍摄画面。
- (6) 长按“拍照”键，文件将会标记为重要文件，循环录像打开时，此文件不会被删除。
- (7) 短按“录音”键，音频记录仪将转到录音模式进行录音。
- (8) 再次短按“录像”键结束录像，机器短振一下，红色指示灯灭，并回到摄像预览状态界面，状态指示灯亮绿色。



录像界面说明



- |          |          |
|----------|----------|
| ① 录像分辨率  | ⑥ 录像时长   |
| ③ 系统当前日期 | ④ ID号水印  |
| ⑤ 录像状态   | ⑦ 电量指示   |
| ⑦ 电量指示   | ⑧ 系统当前时间 |
| ⑨ 卡剩余容量  | ⑩ 卡标志    |
| ⑪ 水印     |          |

## 6 拍照

当您初次使用录音视频记录仪拍照时，请注意本节中的内容说明！在摄像预览状态下，直接按拍照键进行拍照，拍照时红色指示灯亮，并发出“咔嚓”一声。在录像状态下，按下拍照键可以抓拍当时拍摄照片，拍照界面如图 1。



图 1

### 注意

- 电池标记符显示空格时，表明低电。低电时系统会自动关机。如果正在录像或者录音，系统自动保存录音文件后再关机。电量不足时，请及时充电。低电关机时显示屏会有相应的提示，显示屏的提示图标如下所示。



### 提示

- 录像前，请先设置所需的录像参数。
- 请先删除一些不必要的文件再录。
- 本机有感光元件，如果红外切换设置为自动切换，当环境光线暗到一定值时，红外灯自动打开。

## 7 录音

当您初次使用音视频记录仪录音时，请注意本节中的内容说明！

- (1) 在摄像预览状态按下“录音键”开始录音；工作状态指示灯将黄灯闪烁；请将内置麦克风对准音源。
- (2) 长按“拍照”键，文件将会标记为重要文件，循环录像打开时，此文件不会被删除。
- (3) 短按“录像”键，音视频记录仪将转到录像模式进行录像。
- (4) 按下“录音”键结束录音，并回到预览界面。

录音参考界面如下图所示：

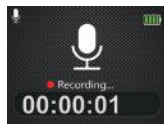

录音界面说明



- ① 录音状态    ② 当前录音时长    ③ 电量指示

### 提示

- 录音前，请先设置所需的录音灵敏度。
- 请先删除一些不必要的文件再录。
- 请先测试录音，以确认音视频记录仪设置是否正确。
- 在录音或者录像过程中禁止直接将卡拔出，否则可能导致文件损坏。
- 录音或者录像时请勿断电，否则这会导致音视频记录仪故障，文件丢失或文件损坏等问题。
- 如果需要长时间使用，请在录音前充电。

## 8 一键回放模式

---

在摄像预览状态下，录像保存后，短按“▶”键，音视频记录仪将直接播放你刚刚摄录的录像文件。录音保存后短按“▶”键，音视频记录仪将直接播放你刚刚录的录音文件。机器刚刚开机启动，一键回放功能默认为播放最近摄录的录像文件。

## 9 视频模式

在摄像预览状态界面中，我们可以使用“◀”键进入查阅回放界面，按“◀”或“▶”键，选择视频选项，然后短按菜单键确认进入视频文件列表界面，视频文件列表参考界面如下图所示：



按“◀”或“▶”键选择需要播放的视频文件，短按菜单键进入视频播放界面，视频播放参考界面如下图所示：



文件的删除需通过连接电脑才可以进行。

录像文件播放界面说明：

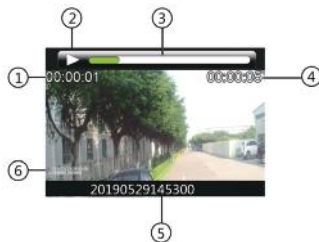

- |        |         |
|--------|---------|
| ① 当前时长 | ② 播放状态  |
| ③ 进度条  | ④ 文件总时长 |
| ⑤ 文件名  | ⑥ ID水印  |

### 9.1 视频播放

- (1) 按“◀”或“▶”键，选择要播放的文件。
- (2) 按菜单键开始播放，工作状态指示灯将亮绿灯。
- (3) 长按菜单键结束播放，并返回视频文件列表界面。
- (4) 播放过程中，按菜单键暂停播放，再次按下菜单键，将继续先前位置的播放。
- (5) 播放时短按“◀”或“▶”键，可选择2倍，4倍，8倍，16倍，



- 32 倍，64 倍，快退或快进当前正在播放的文件。
- (6) 长按“拍照”键即可将当前选中文件标记为重要文件，循环录像打开时，此文件不会被覆盖。只有通过连接电脑才可以删除该文件。

## 10 照片模式

在摄像预览状态界面中，我们可以使用“◀”键进入查阅回放界面，按“◀”或“▶”键，选择拍照选项，然后短按菜单键确认进入。然后，短按菜单键进入拍照文件列表界面，拍照文件列表参考界面如下图所示：



按“◀”或“▶”键选择需要播放的照片文件，短按菜单键进入照片浏览状态，按“◀”或“▶”键选择要查看的照片。照片回放界面下，长按“拍照”键即可将当前选中文件标记为重要文件，循环录像打开时，此文件不会被覆盖。只有通过连接电脑才可以删除该文件。

## 11 语音模式

在摄像预览状态下，你可以使用菜单键进入查阅回放界面，按“◀”或“▶”键，选择录音回放选项，然后短按菜单键确认进入语音文件列表界面，语音文件列表参考界面如下图所示：



按“◀”或“▶”键选择需要播放的音频文件，短按菜单键进入语音播放停止界面，再次短按菜单键进入语音播放界面，语音播放参考界面如下图所示：

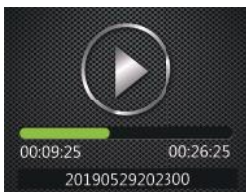

语音文件播放界面说明：

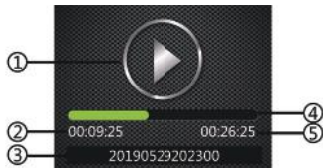

- ① 播放状态
- ② 当前播放时长
- ③ 时间文件名
- ④ 播放进度条
- ⑤ 文件总时长

### 11.1 语音播放

- (1) 按“◀”或“▶”键，选择要播放的文件。
- (2) 按菜单键开始播放，工作状态指示灯将亮绿灯。
- (3) 长按菜单键结束播放。并返回语音文件列表界面。
- (4) 播放过程中，按菜单键暂停播放，再次按下菜单键，将继续先前位置的播放。
- (5) 长按“拍照”键即可将当前选中文件标记为重要文件，循环录像打开时，此文件不会被覆盖。只有通过连接电脑才可以删除该文件。

## 12 对讲机

本音视频记录仪带有独立的对讲机功能。对讲机的频道，亚音频等在音视频记录仪中设置，当音视频记录仪关机时，仍然可以进行语音对讲。

### 12.1 对讲机功能开关

将对讲机开关键往天线方向旋转，对讲机会发出一个提示音，提示对讲机已经开启，这时候按住PTT键，对讲机指示灯亮红色灯，表示对讲机发射语音。PTT键没有按下，如果对讲机指示灯亮红色灯时，表示对讲机接收到语音，并且喇叭会相应接收到的语音。往反的方向调节到底将关闭对讲机。对讲机开启后，音视频记录仪预览界面参考示意图如下图所示：



### 12.2 对讲机设置

当对讲机和音视频记录仪都开启后，可以在菜单的对讲机设置栏中设置对讲机相应的值。只有对讲机开启后才能在菜单的对讲机设置栏中进行设置，对讲机关闭时，菜单的对讲机设置栏中的选项变成灰色不可选。

### 12.3 对讲音量调节

对讲机开启后，往对讲机天线方向旋转调大对讲机音量，往反方向调节将会调小音量。使用合适的音量对讲，对讲语音更清晰。

#### 提示

- 对讲机指示灯红灯闪烁时，说明对讲机已经低电，请及时充电。低电状态下，如果您还想继续使用音视频记录仪进行摄录，请先将对讲机关机。
- 对讲机处于低电状态时，对讲指示灯，红灯持续闪烁几十秒后，对讲机将会自动关机。充满电后，继续使用对讲机功能时，请先将对讲机开关重新关闭再打开，来启动对讲机功能。

## 13 设置模式

### 13.1 对讲机设置

本音视频记录仪带有独立的对讲机功能，如果对讲机处于关闭状态，对讲机设置栏中的选项变成灰色，不能进行设置，需要把对讲机开启才能进行设置。

对讲机设置菜单栏包括：公众频道、远距离频道、亚音码、发射限时和静噪级别。选择对讲机设置菜单，按菜单键确认进入，按“◀”或“▶”键选择所需要设置的选项，然后按菜单键确认进入。

#### 13.1.1 公众频道

公众频道主要是用于短距离对讲的频道，本音视频记录仪的公众频道范围为：“409.7500MHz~409.9875 MHz”。按左键或右键选择合适的频率，选择完成后按菜单键确定，长按菜单键键可返回上一级菜单。



#### 13.1.2 远距离频道

远距离频道主要是用于对讲距离比较远时的频道，本音视频记录仪的远距离频道范围为：430.1375 MHz~439.4375 MHz。



---

### 13.1.3 亚音码

亚音的作用主要是开启静噪，这样即提高灵敏度又避免干扰和噪音。亚音码开启后，只有收发双方的亚音码值相同时，才能接收到对方发出的对讲语音。亚音码菜单选项有关闭，模拟亚音，数字亚音三个选项。

---

### 13.1.4 发射限时

对讲机的发射限时功能用于限制用户在一信道上超时间发射，同时也避免对讲机因长时间发射而影响使用体验。



---

### 13.1.5 静噪级别

静噪的目的固然是为了严格抑制噪声，但如果抑制过度就会使

微弱的通话信号也会限制从而接收不到。静噪功能有不同的静噪等级，可根据实际情况自行调节。

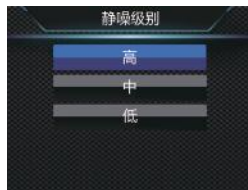

---

## 13.2 录音设置

录音设置菜单栏包括：录音类型，麦克灵敏度。选择设置菜单，按菜单键确认进入，按“◀”或“▶”键选择所需设置的选项，然后按菜单键确认进入。

---

### 13.2.1 录音类型

在录音类型菜单中有两种录音类型可供选择：“高品质、长时间”。如果机器录音时，则在录音达到一个小时后，机器自动保存录音文件，然后进行下一个录音。参考界面如下图所示：



高品质：WAV 格式，高音质，比特率为 1536kbps。

长时间：WAV 格式，一般音质，比特率为 385kbps。

### 13.2.2 麦克灵敏度

在麦克灵敏度菜单中有三种增益可供选择：“高”，“中”，“低”。

选择不同的麦克灵敏度可以达到不同的录音效果。



## 13.3 录像设置

录像设置菜单栏包括：分辨率，视频质量，视频预览，视频延录。

选择录像设置菜单图标，按菜单键确认进入，按“◀”或“▶”键选择所需设置的选项，然后按菜单键进入。

### 13.3.1 分辨率

录像分辨率有 2304×1296 30P、2560×1080 30P、1920×1080 30P、1280×720 60P、1280×720 30P、848×480 60P、848×480 30P 七个级别，多种录像分辨率选择，可满足大部分应用场合，按“◀”或“▶”键选择按键选择合适的分辨率，选择完成后按菜单键确定，长按菜单键可返回上一级菜单。

参考界面如下图所示：



### 13.3.2 视频质量

在视频质量菜单中有三种画质可供选择：“超精细，良好，正常”。根据不同的需求选择不同的画质效果，画质越好，相同录像时间所占的内存越大。

### 13.3.3 视频预录

使用视频预录功能，你可以提前录制事件触发前十几秒到几十秒的画面，视频预录有关闭和打开两种选择，按“◀”或“▶”键进行选择，选择完成后按菜单键确定，长按菜单键可返回上一级菜单。

### 13.3.4 视频延录

使用视频延录功能，你可以在按下按键保存录像后继续拍摄设定的时间，视频延录设置关闭、5秒、10秒、15秒、30秒、60秒六个选择，按“◀”或“▶”键进行选择，选择完成后按菜单键确定，长按菜单键可返回上一级菜单。

### 13.4 拍照设置

拍照设置菜单栏包括：照片大小，照片质量，连拍，自拍。选择拍照设置菜单图标，按“◀”或“▶”键选择所需设置的选项，然后按菜单键进入。

#### 13.4.1 照片大小

拍照照片的大小分为32M、23M、20M、18M、16M、14M、12M、8M、5M、3M这10个级别，按“◀”或“▶”键选择按键选择合适的分辨率，选择完成后按菜单键确定，长按菜单键可返回上一级菜单。参考界面如下图所示：



#### 13.4.2 照片质量

在拍照设置菜单中，选择“照片质量”菜单，再按菜单键进入



照片质量菜单。在视频质量菜单中有三种画质可供选择：“超精细”，良好，正常”。根据不同的需求选择不同的画质效果，画质越好，相同录像时间所占的内存越大。

### 13.4.3 连拍

连拍是指在取景预览模式下或在录像过程中，按一次拍照键相机能够连续拍摄照片。

在拍照设置菜单中，选择“连拍”菜单，再按菜单键进入连拍菜单。连拍设置可以设置关闭、3张、5张、10张、20张五个选择，按“◀”或“▶”键选择合适的连拍张数，选择完成后按菜单键确定，长按菜单键可返回上一级菜单。

### 13.4.4 自拍

自动拍照是指在取景预览模式下或在录像过程中，按一次拍照键相机每隔一定的时间拍摄一张照片，直到按下拍照键取消或者卡满和没电为止。

自动拍照可以设置关闭、3秒、5秒、10秒、30秒、60秒六个选择，按“◀”或“▶”键选择合适的秒数，选择完成后按菜单键确定，长按菜单键可返回上一级菜单。

## 13.5 系统设置

系统设置菜单栏包括：语言，系统制式，默认设置，屏亮度，系统时间，自动关机，自动关屏，音量，车载模式，循环录像，车载录音，分段录像，按键音，指示灯，红外切换，移动侦测，曝光补偿，ID号和系统信息。选择系统设置菜单图标，按“◀”或“▶”键选择所需设置的选项，然后按菜单键进入。

### 13.5.1 语言

在语言选择菜单中，你可以选择一种语言作为系统语言。语言选择参考界面如下：



---

### 13.5.2 系统制式

系统制式也称电视广播制式，有 NTSC 和 PAL 两大制式，机器做为电视输出时要根据电视机的制式选择正确的选项。

---

### 13.5.3 默认设置

使用此功能，你可以重置机器的设置选项。

---

### 13.5.4 屏亮度

使用此功能，可以根据需要调节显示屏的亮度。屏亮度设置可以设置高、中、低三个级别，按“◀”或“▶”键选择合适的选项，选择完成后按菜单键确定，长按菜单键可返回上一级菜单。

---

### 13.5.5 系统时间

系统时间设置界面，参考图片如下：



在此界面下，长按“≡”返回上一级菜单，按“◀”或“▶”键调整相应位置的数值，短按“≡”选择年、月、日、时、分，当连续按“≡”到“分钟选项后”，再按一次“≡”确认更改，并返回上一级菜单。

---

### 13.5.6 自动关机

如果在设定的时间内没对机器做任何操作，系统将会自动关机。自动关机设置参考界面如下：



### 13.5.7 自动关屏

自动关屏时间有五种时长可供选择：关闭、1分钟、3分钟和5分钟。如果在设定的时间内没对机器做任何操作，显示屏将会自动灭。如果选择“关闭”，显示屏将会常亮。

### 13.5.8 音量

使用此功能，你可以设置机器的输出音量。

音量设置可以从0~16之间17个数值选择，按“◀”或“▶”键选择合适的音量值，选择完成后按菜单键确定。

### 13.5.9 循环录像

在录像设置菜单中，选择“循环录像”菜单，再按菜单键进入循环录像菜单。有关闭和打开两种选择，按“◀”或“▶”键进行选择，选择完成后按菜单键确定，长按菜单键返回上一级菜单。



### 13.5.10 车载录音

使用此功能，你可以选择是否需要录下车内的声音。

### 13.5.11 分段录像

视频分段有5分钟、10分钟、15分钟、20分钟、30分钟五个级别，在录像过程中，视频分段在每所设定的时间自动将视频文件分段保存并自动进入下一个文件录像，并且是无缝切换。视频分段功能参考界面如下图所示：



---

### 13.5.12 按键音

使用此功能，按键操作将会有声音提示。

---

### 13.5.13 指示灯

使用此功能，你可以根据需要打开或者关闭状态指示灯。

---

### 13.5.14 红外切换

在系统设置菜单中，按“◀”或“▶”键选择“红外”菜单，再按菜单键进入红外切换菜单。红外切换可以设置手动、自动两种选择，选择完成后按菜单键确定，长按菜单键可返回上一级菜单。

---

### 13.5.15 移动侦测

音视频记录仪在待机状态下，有物体进入音视频记录仪拍摄范围内后自动开启录像功能，物体离开音视频记录仪拍摄范围后结束录像功能并保存录像文件。移动侦测功能设置可选择：关闭 / 开启。

---

### 13.5.16 曝光补偿

曝光补偿是一种曝光控制方式，曝光补偿可以让照片更明亮或者更昏暗的拍摄手法。可以根据自己的想法调节照片的明暗程度，创造出独特的视觉效果等。

曝光补偿设置可以从  $-2.0$ ~ $+2.0$  之间 13 个数值选择，按“◀”或“▶”键选择合适的曝光值，选择完成后按菜单键确定。

---

### 13.5.17 ID 号

ID 号设置界面，参考图片如下：



在此界面下，长按菜单键返回上一级菜单，按“◀”或“▶”键调整相应位置的数值，短按菜单键选择相应的数字位置，当连续按菜单键到最后一位数字位置后，再按一次菜单键确认更改，并返回上一级菜单。

### 13. 5. 18 系统信息

系统信息菜单中包括：总存储容量，可用空间，可用录像时间，可用录音时间，电池电量和版本号。

总存储容量：你可以查看本机内存大小信息。

可用空间：你可以查看剩余空间信息。

可用录像时间：你可以查看当前录像分辨率可以录像多久。

可用录音时间：你可以查看当前录音类型可以录音多久。

电池电量：你可以查看当前电池电量信息。

版本号：你可以查看固件版本信息。

## 14 背夹的装取

---

装背夹时将背夹插片的 R 位导入主机槽口后，缓慢推进背夹直至插片顶到插槽底部为止。

如下图所示：

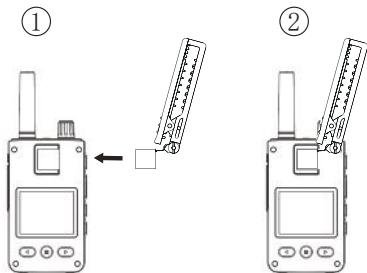

---

### 14.2 取下背夹

取出背夹时，一手握住背夹，一手握住主机并扶住插片，轻缓拔出即可。

## 15 背夹的佩戴方法

- (1) 压住手夹位使夹子口张开，然后朝着肩章夹入，使夹钩勾住肩章纽扣的根部。

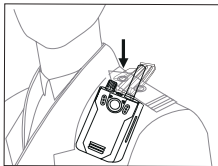

- (2) 松开手夹位，使夹子夹住肩章，并将机器调整至合适的位置。

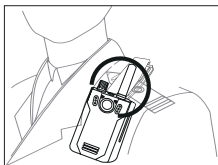

## 16 常见问题

---

此处列举了常见问题的解答，可帮助解决音视频记录仪出现的简单问题。如果故障仍无法排除，请咨询经销商或访问我们的官方网站：[www.philips.com/support](http://www.philips.com/support)

---

### 16.1 无法启动音视频记录仪

电池电量已耗尽请及时充电。

---

### 16.2 显示时间 / 日期不正确

音视频记录仪时间不准确，请在菜单上重新设置时间。

---

### 16.3 拍照 / 录像图像模糊，不清楚

镜头不干净。请用干净的绒布清洁镜头。

---

### 16.4 音视频记录仪无法录音或者录像

音视频记录仪存储空间已满并且未开启循环录像。请删除部分文件或将其移至外部存储设备。

---

### 16.5 音视频记录仪无法播放录音或者录像

电池电量已耗尽，请充电。

---

### 16.6 音视频记录仪死机后如何处理

你有时在操作中会遇到开不了机，黑屏，操作不了等死机现象，通常处理方法是，复位一下。复位前，需要先把对讲机关掉，复位位置：将耳机 /USB/Micro SD 卡胶塞打开，在 USB 口和 Micro SD 卡中间的上方有一个小孔，用水性笔头等东西点按一下小孔即可。



## 17 技术参数

---

### 17.1 存储器

外置存储空间

参考录音时间（16GB）：录音时间约 86 小时

内置存储器类型：C10 TF 卡

移动存储器（PC）：是

---

### 17.2 尺寸和重量

宽 × 高 × 深：58×100×26（mm）

重量（含电池）：203g（不含背夹）

---

### 17.3 系统要求

操作系统：Windows 7/8/10/Vista/XP/2000, Mac OS X, Linux

接口：USB 接口

---

### 17.4 录音

高品质：比特率为 1536kbps，格式为 WAV

长时间：比特率为 384kbps，格式为 WAV

---

### 17.5 运行条件

温度：-30℃ ~ 55℃

空气湿度：10% - 90%，不凝结

# Content

---

<b>1 Welcome</b>	<b>36</b>
1.1 Product features	36
<b>2 Important Notice</b>	<b>37</b>
2.1 Safety	37
2.2 Hearing protection	37
2.3 Legal restriction on recording	37
2.4 Install antenna	38
<b>3 Your Audio/Video Recorder</b>	<b>39</b>
3.1 What's in the box:	39
3.2 Overview of your audio recorder:	39
<b>4 Start to Use</b>	<b>41</b>
4.1 Turn on/off	41
4.2 Charging methods	42
4.3 Connecting to computer	42
<b>5 Video Recording</b>	<b>43</b>
<b>6 Camera</b>	<b>44</b>

---

<b>7 Voice Recording</b>	<b>45</b>
<b>8 One-click Playback Mode</b>	<b>46</b>
<b>9 Video Mode</b>	<b>47</b>
9.1 Video playing	47
<b>10 Photo Mode</b>	<b>49</b>
<b>11 Audio Mode</b>	<b>50</b>
11.1 Voice play	51
<b>12 Interphone</b>	<b>52</b>
12.1 Interphone function switch	52
12.2 Interphone setting	52
12.3 Interphone volume adjustment	52
<b>13 Setting Mode</b>	<b>54</b>
13.1 Interphone setting	54
13.2 Audio recording setting	55
13.3 Video recording setting	56
13.4 Camera setting	57
13.5 System setting	59

---

14	Mounting of Shoulder Clip	64
----	---------------------------	----

---

15	Wearing Shoulder Clip	65
----	-----------------------	----

---

16	Frequently Asked Questions (FAQ)	66
16.1	Failure to start the recorder	66
16.2	Incorrect time/date	66
16.3	Unclear image	66
16.4	Failure to record audio/video	66
16.5	Recorder is unable to play audio or video files	66
16.6	Failure to record audio/video	66

---

17	Technical Parameter	67
17.1	Memory	67
17.2	Size & weight	67
17.3	System requirements	67
17.4	System requirements	67
17.5	Memory	67

## I Welcome

---

Welcome to the world of Philips! We are honored by your choice and purchase of Philips' products. You can have Philips' comprehensive technical supports from our website, e.g. user's manuals, software downloading and warranty information etc.

[www.philips.com](http://www.philips.com)

---

### 1.1 Product features

- One-click Voice Recording: Simply press the Voice Recording button for the first time to record, and the second time to save recorded clips.
- One-click Video Recording: Simply press the Video Recording button for the first time to record, and the second time to save recorded clips.
- One-click playback function: After audio or video recording, press the right button to enter file play directly.
- Professional audio codec to achieve high quality recording.
- The independent interphone function realizes the true integration of an audio/video recorder and an interphone.
- 145° super-wide-angle lens to get a fuller picture.
- Use the dual filter switch to prevent color cast during daytime and ensure more clarity during nighttime.
- 3.5mm standard headphones ensure clearer sound under noisy environment during replay.
- On-Screen Display function ensures that all videos and photos contain un-editable timing, product serial number and user serial number that ensure the legal validity of such evidence.
- Super long file name: All recorded video files contain information such as product serial number, recording time and user serial number, which ensure convenient data storage and retrieval.
- All recorded video files are automatically cut and saved to prevent data loss due to incorrect operation.
- The external VTR8300 memory card supports up to 128G.
- High-definition speaker: A high-quality vibration speaker is used, and plays audio or video files vividly.
- Record in a common WAV format.
- Access to the audio file and data by using high-speed USB 2.0.
- It is able to be used as a large capacity USB storage device to ensure maximum compatibility.

## 2 Important Notice

---

### 2.1 Safety



#### Notice

- This icon means that users have to exercise caution when handling or operating the device.



#### Warning

Special Announcement: Before using the product, please read the Manual carefully. The Company shall not be held liable for any data loss due to incorrect manual operation or force majeure. We specially recommend that users make additional copies of the files in the device.

---

### 2.2 Hearing protection

Observe the following guidelines when using your headphones:

- Adjust to a suitable volume; do not use the headphones for a long time.
- Please do not turn the volume up beyond your tolerance.
- Do not turn up the volume so high that you cannot hear what's around you.
- Be careful or suspend the use of headphones in hazardous situations.
- Do not use the earphone when driving, cycling or skateboarding. Otherwise, you will get into a traffic accident or be violating traffic laws and other related laws.

---

### 2.3 Legal restriction on recording

- The use of the recording function of this device is subject to the restrictions imposed by national laws. When recording the conversations or courses of others, users should respect the privacy and other rights of such persons.
- Please note that in some countries, the user must notify the other party when he/she is recording his/her conversations with such other party. Otherwise, such a recording activity might be considered illegal. Please ensure the lawfulness of the recording activity in any applicable jurisdiction.

## 2.4 Install antenna

To order to facilitate packaging and transportation, the inter-phone antenna of the audio recorder is placed separately. The customer needs to install the antenna to use the interphone. The specific operation is as follows:

①



②

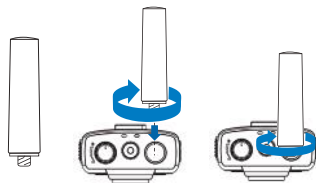

### Notice

- Under the condition that the antenna is tight and not loose, it does no need to be twisted all the time to avoid damage.
- Do not move the antenna to one side to avoid breaking and affecting the signal.

### 3 Your Audio/Video Recorder

#### 3.1 What's in the box:

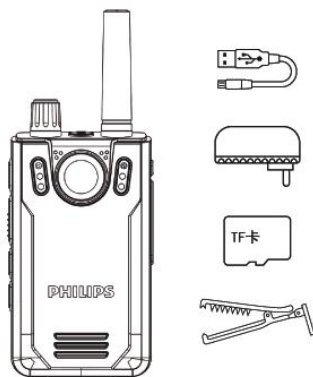

#### 3.2 Overview of your audio recorder:

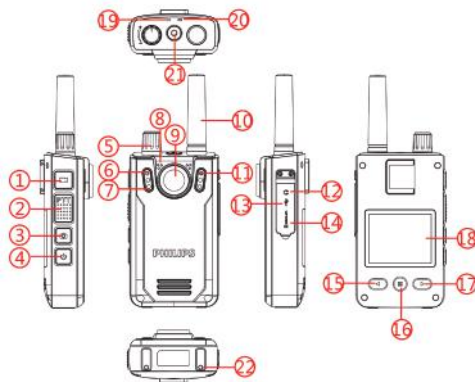

- ① Video recording button
- ② PPT group chat button
- ③ Camera button
- ④ Power on/off button
- ⑤ Interphone switch / Interphone volume adjustment button
- ⑥ Photoresistor
- ⑦ Infrared light
- ⑧ Microphone
- ⑨ Camera
- ⑩ Interphone antenna
- ⑪ White light
- ⑫ Headphone socket
- ⑬ USB port
- ⑭ TF card socket
- ⑮ Previous track/Fast reverse/Zoom-out /Menu selection button
- ⑯ Menu/Enter/Play/Pause/Return button
- ⑰ Next track/Fast forward/Zoom-in/Menu selection button
- ⑱ Display screen
- ⑲ Recorder status indicator
- ⑳ Interphone status indicator
- ㉑ Recording button
- ㉒ Desktop charging contact



## 4 Start to Use

### 4.1 Turn on/off



#### Notice

- Please charge the device in the shutdown mode for three hours before using it for the first time!

During shutdown mode, hold down Turn ON button for 3 seconds, and the device will be turned on immediately, showing the Philips logo, as shown below:



The device then enters the preview screen, as shown below; in the preview mode, the operating status indicator will be illuminated in green. Press the “≡” button on this screen, and the device will return to the setting screen. In the preview

screen, hold down the “◀” or “▶” button to enter the zoom-in/zoom-out and realize the digital zooming function.



#### Reminder

- The device is powered by the built-in lithium battery; if the device is not to be used for a long time, hold down the Turn On/Off button for 3s to shut down the device.
- If the recorder does not work properly, please check if the device is out of power.
- During operation please do not pull out the external memory card. Otherwise, damage might be caused to the files or the device.
- When the battery indicator “” is displayed, please charge the device promptly.

## 4.2 Charging methods

- (1) During shutdown mode, use USB data cable and the connector to charge the device. The device indicator will show green light first during charging, which will be extinguished after the device is fully charged.
- (2) If the USB data cable is used to connect the device to the provided charger for charging with the device powered on, the battery icon on the screen will be changing during charging. When the device is fully charged, the battery icon will no longer change.



### Reminder

- The device can be charged either during ON or OFF mode. Normally, during OFF mode charging, it takes around 3 hours for full charging. During ON mode charging, it takes around 5 hours for full charging (we recommend that users use OFF mode charging).

## 4.3 Connecting to computer

The recorder can be used as a large-volume USB storage device, which can be connected to the computer. No software needs to be installed for VTR8400. The recorder can

automatically be recognized as a portable device. The icon when the device is connecting to the computer is as shown below.



### Reminder

- When a file moves into or out from the device, do not disconnect the device from the computer.
- Connect the device to the computer using the USB data cable after starting the device, or hold down the Power button for 3s after connecting the device to the computer using the USB data cable.
- If a 16-64GB TF card is to be formatted, select the file system option of FAT32 for formatting. If the card capacity is 128GB, select the file system option of exFAT for formatting. Do not use the NTFS format, otherwise, the device cannot perform audio/video recording.

## 5 Video Recording

When you use the recorder for the first time, please pay attention to the requirements in this section!

- (1) In the camera preview mode, press the “Video Recording” button to start video recording, and the status indicator will flash in red.
- (2) Hold down the “◀” or “▶” button to enter the zoom-in/zoom-out preview screen and realize the digital zooming function.
- (3) During video recording at night or in a dark environment, if infrared switching is manual, hold down the “Audio Recording” button, the infrared lamp will turn on, the device will enter the night vision video recording mode, and the screen color will be monochrome.
- (4) During video recording at night or in a dark environment, hold down the “Video Recording” button. The illumination lamp will turn on as a supplementary light source.
- (5) Press the “Camera” button to capture the current video recording screen.
- (6) Hold down the “Camera” button to mark the file as an important file; when the cyclic video recording is turned on, this file will not be deleted.
- (7) Press the “Audio Recording” button, the device will switch to the audio recording mode for audio recording.
- (8) Press the “Video Recording” button again to end video

recording. The device will vibrate briefly, the red indicator will go out, the device will return to the camera preview mode screen, and the status indicator will be illuminated in green.



Recording Interface Illustration:



- |                          |                            |
|--------------------------|----------------------------|
| ① Battery indicator      | ② Card icon                |
| ③ Residual card capacity | ④ Video recording icon     |
| ⑤ Watermark              | ⑥ ID No. watermark         |
| ⑦ Recording resolution   | ⑧ Video recording duration |
| ⑨ Current date of system | ⑩ Current time of system   |
| ⑪ Recording mode         |                            |

## 6 Camera

When you use the device for photo taking for the first time, please read the instructions in this section! In the camera preview state, directly press the camera button to take a photo. In the state of photo taking, the red indicator lights on, and the device makes a sound of 'beep'. In the video recording state, press the camera button to capture the picture at the time. The interface of which is shown as Figure 1.



Figure 1



### Notice

- When the battery icon is showing empty, it means low on battery. The system will shut down automatically at low power. If users are recording, the system will automatically save the recorded files and then shut down. In case of a low battery, please charge the device timely. During low battery, the device gives the "Low Battery" notice as shown below:



### Reminder

- Before recording, please adjust the recording parameters first.
- Please delete some unnecessary files before recording.
- The device has a photosensitive element; if infrared switching is set as automatic switching, the infrared lamp will turn on automatically when ambient light drops to a certain value.

## 7 Voice Recording

When users use the device for audio recording for the first time, please read the instructions in this section!

- (1) Press the “Audio Recording” button in the camera preview mode to start audio recording; the operating status indicator will flash in yellow; please align the built-in microphone with the sound source.
- (2) Hold down the “Camera” button to mark the file as an important file; when the cyclic video recording is turned on, this file will not be deleted.
- (3) Press the “Video Recording” button. The device will switch to the video recording mode for video recording.
- (4) Press the “Audio Recording” button to end audio recording, and return to the preview screen.

The reference audio recording interface is shown below:



Audio Recording Illustration:



- ① Recording state
- ② Current recording duration
- ③ Battery indicator



### Reminder

- Before audio recording, set the required audio recording sensitivity.
- Please delete some unnecessary files before recording.
- Please first test audio recording to see if the device is set properly.
- Do not pull out the memory card during the audio/video recording mode. Otherwise, damage might be caused to the files.
- Do not cut off power during audio/video recording mode. Otherwise, the damage might be caused to the recorder and the files might be lost or damaged.
- If users intend to use the device for a long period of time, please charge the device before recording.

## 8 One-click Playback Mode

---

In the camera preview mode, press the “▶” button after the video record is saved, and the device will play the video file that users have just recorded directly. Press the “▶” button after the audio record is saved, and the device will play the audio file that users have just recorded directly. When the device is just turned on, the one-click playback function will play the most recently recorded video file by default.

## 9 Video Mode

In the camera preview mode screen, users can use the “◀” button to enter the search and playback screen, press the “◀” or “▶” button to select a video option, and then press the Menu button to enter the video file list screen. The reference video file list screen is as shown below:



Press the “◀” or “▶” button to select the video file to be played, and press the Menu button to enter the video play screen. The reference video play screen is as shown below:



This file can be deleted only when the computer is connected.

Interface illustration of recorded file playing:

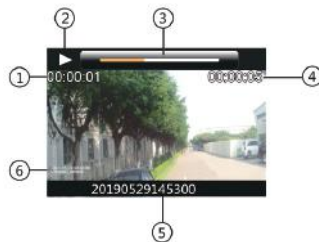

- ① Current duration
- ② Current play status
- ③ Progress bar
- ④ Overall duration of file
- ⑤ File name
- ⑥ ID watermark

### 9.1 Video playing

- (1) Press “◀” or “▶” to select the file you need to play.
- (2) Press the “Menu” button to start playback, and the working indicator will light on in green.
- (3) Hold down the Menu button to end playing, and return to the video file list screen.
- (4) During play, press the Menu button to pause, and press it

again to resume play from the previous position.

- (5) Press “◀” or “▶” button during play to fast reverse or fast forward the file being played at 2X, 4X, 8X, 16X, 32X or 64X.
- (6) Hold down the “Camera” button to mark the currently selected file as an important file; when the cyclic video recording is turned on, this file will not be overridden. This file can be deleted only when the computer is connected.



## 10 Photo Mode

In the camera preview mode screen, users can use the “◀” button to enter the search and playback screen, press the “◀” or “▶” button to select a camera option, and then press the Menu button to enter. Then press the Menu button to enter the photo file list screen. The reference photo file list screen is as shown below:



Press the “◀” or “▶” button to select the photo file to be played, press the Menu button to enter the photo browse mode and press the “◀” or “▶” the button to select the photo to be viewed.

In the photo playback screen, hold down the “Camera” button to mark the currently selected file as an important

file; when the cyclic video recording is turned on, this file will not be overridden. This file can be deleted only when the computer is connected.

## 11 Audio Mode

In the camera preview mode screen, users can use the Menu button to enter the search and playback screen, press the “◀” or “▶” button to select an audio recording playback option, and then press the Menu button to enter the audio file list screen. The reference audio file list screen is as shown below:

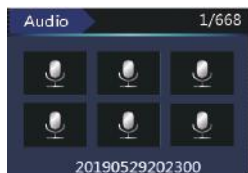

Press the “◀” or “▶” button to select the audio file to be played, press the Menu button to enter the audio play stop screen, and press the Menu button again to enter the audio play screen. The reference audio play screen is as shown below:

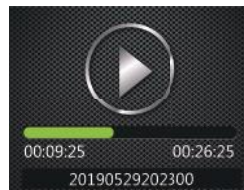

Interface illustration of audio file playing:

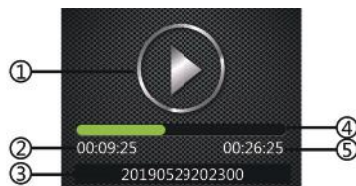

- ① Play status
- ② Current play time
- ③ Name of time file
- ④ Play progress bar
- ⑤ Overall duration of file

---

## 11.1 Voice play

- (1) Press '◀' or '▶' button to select the file you want to play.
- (2) Press the Menu button to start play, and the operating status indicator will be illuminated in green.
- (3) Hold down the Menu button to end playing. And return to the audio file list screen.
- (4) During play, press the Menu button to pause, and press it again to resume play from the previous position.
- (5) Hold down the "Camera" button to mark the currently selected file as an important file; when the cyclic video recording is turned on, this file will not be overridden. This file can be deleted only when the computer is connected.

## 12 Interphone

---

The device has an independent interphone function. The channel, subsonic code, etc. of the interphone are set in the device; when the device is turned off, voice intercommunication is still possible.

---

### 12.1 Interphone function switch

Turn the interphone switch toward the antenna, and the interphone will give a prompt tone, indicating that the interphone has been turned on. At this point, press the PTT button, and the interphone indicator will be illuminated in red, indicating that the interphone is transmitting audio. If the PTT button is not pressed and interphone indicator lights up in red, it means the interphone has received an audio, and the speaker will play the received audio. Turning in the reverse direction will turn off the interphone. The reference preview screen of the device after the interphone is turned on is as shown below:



---

### 12.2 Interphone setting

When both the interphone and the recorder are turned on, users can set the interphone in the interphone setting bar of the menu. Setting in the interphone setting bar of the menu is possible only when the interphone is turned on; when the interphone is turned off, the options in the interphone setting bar of the menu will become gray and cannot be selected.

---

### 12.3 Interphone volume adjustment

After the interphone is turned on, turn it toward the interphone antenna to increase its volume, and in the reverse direction to reduce its volume. Intercommunicate with a proper volume for a clearer voice.



#### Reminder

- When the red indicator of the interphone is flashing, it means that the interphone has low power. Please charge it in time. If you want to continue to use the device for recording under low power condition, please turn off the interphone first.
- When the interphone is in low power state, it will automatically shut down after the red indicator keeps flashing for seconds. When you continue to use the interphone function after being fully charged, please turn the interphone switch off and then reopen it to start the interphone function.

## 13 Setting Mode

---

### 13.1 Interphone setting

The device has an independent interphone function. When the interphone is turned off, the options in the interphone setting bar will become gray and cannot be set; they can be set only if the interphone is turned on.

The interphone setting menu bar includes public channel, long-distance channel, subsonic code, timeout timer and squelch level. Select the interphone setting menu, press the Menu button to enter, press the “◀” or “▶” button to select the option to be set, and then press the Menu button to enter.

---

#### 13.1.1 Public channel

The public channel is used mainly for short-distance intercommunication. The frequency range of the public channel of the device is 409.7500~409.9875MHz. Press the left or right button to select an appropriate frequency, then press the Menu button for confirmation, and hold down the Menu button to return to the previous menu.



---

#### 13.1.2 Far distance

The long-distance channel is used mainly for long-distance intercommunication. The frequency range of the long-distance channel of the device is 430.1375~439.4375 MHz.



### 13.1.3 Subsonic code

Subsonic is used mainly to turn on squelch to both improve sensitivity, and avoid interference and noise. After the subsonic code is turned on, only if the sender and the receiver have the same subsonic code value can they receive intercommunication audios from each other. The subsonic code menu has three options: off, analog subsonic and digital subsonic.

### 13.1.4 Time limited

The timeout timer function of the interphone is used to prevent the user from transmission timeout on a single channel, and also to protect user experience from the prolonged transmission of the interphone.



### 13.1.5 Squelch level

Although squelch is intended to inhibit noise strictly, over-inhibition may prevent weak communication signals from being received. The squelch function has different squelch levels and may be adjusted as necessary.



### 13.2 Audio recording setting

The audio recording setting menu bar includes audio recording type and microphone sensitivity. Select the setting menu, press the Menu button to enter, press the "◀" or "▶" button to select the option to be set, and then press the Menu button to enter.

---

### 13.2.1 Audio recording type

The audio recording type has two options: HQ and SLP. When audio recording has reached one hour, the device will save the audio file automatically, and then begin to record the next audio. The reference screen is as shown below:

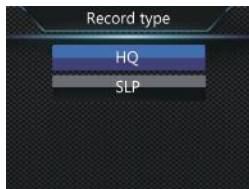

HQ: WAV format, high sound quality, with a bit rate of 1536kbps.

SLP: WAV format, ordinary sound quality, with a bit rate of 385kbps

---

### 13.2.2 Microphone sensitivity

The microphone sensitivity menu has three gain options: high, medium and low. Selecting a different microphone sensitivity will realize a different audio recording effect.

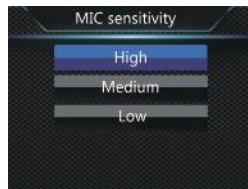

---

## 13.3 Video recording setting

The video recording setting menu bar includes resolution, video quality, video pre-recording and video delayed recording. Select the icon of the video recording setting menu, press the Menu button to enter, press the “◀” or “▶” button to select the option to be set, and then press the Menu button to enter.

---

### 13.3.1 Resolution

Five video recording resolutions are available: 2304×1296 30P, 2560×1080 30P, 1920×1080 30P, 1280×720 60P, 1280×720 30P, 848×480 60P, and 848×480 30P, which can suit most applications. Press the “◀” or “▶” button to select an



appropriate resolution, then press the Menu button for confirmation, and hold down the Menu button to return to the previous menu.

The reference screen is as shown below:



### 13.3.2 Video quality

The video quality menu has three picture quality options: ultra-fine, fine and normal. Please select a picture quality option based on your needs. The better picture quality is, the more memory will be occupied in the same video recording time.

### 13.3.3 Video pre-recording

With the video pre-recording function, users can record a video from over ten to tens of seconds before an event is triggered. Two video pre-recording options are available: off

and on. Press the “◀” or “▶” button for selection, then press the Menu button for confirmation and hold down the Menu button to return to the previous menu.

### 13.3.4 Delayed video recording

With the video delayed recording function, users can press a button to save the set time of continued shooting after video recording. Six video delayed recording options are available: off, 5s, 10s, 15s, 30s, and 60s. Press the “◀” or “▶” button for selection, then press the Menu button for confirmation and hold down the Menu button to return to the previous menu.

### 13.4 Camera setting

The camera setting menu bar includes photo size, photo quality, continuous shooting, and automatic shooting. Select the camera setting menu icon, press the “◀” or “▶” button to select the option to be set, and then press the Menu button to enter.

---

### 13.4.1 Photo size

10 photo sizes are available: 32M, 23M, 20M, 18M, 16M, 14M, 12M, 8M, 5M and 3M. Press the “◀” or “▶” button to select an appropriate resolution, then press the Menu button for confirmation and hold down the Menu button to return to the previous menu. The reference screen is as shown below:



---

### 13.4.2 Photo quality

In the camera setting menu, select the “photo quality” menu, and then press the Menu button to enter the photo quality menu. The video quality menu has three picture quality options: ultra-fine, fine and normal. Please select a picture quality option based on your needs. The better picture quality is, the more memory will be occupied in the same video recording time.

---

### 13.4.3 Continuous shooting

Continuous shooting means that the device can take photos continuously when the Camera button is pressed once in the preview mode or during video recording.

In the camera setting menu, select the “continuous shooting” menu, and then press the Menu button to enter the continuous shooting menu. Five continuous shooting options are available: off, 3 photos, 5 photos, 10 photos, and 20 photos. Press the “◀” or “▶” button to select an appropriate number of photos, then press the Menu button for confirmation and hold down the Menu button to return to the previous menu.

---

### 13.4.4 Automatic shooting

Automatic shooting means that the device can take a photo at a certain interval when the Camera button is pressed once in the preview mode or during video recording until the Camera button is pressed again for cancellation, the card is full or the battery runs out.

Five automatic shooting options are available: off, 3s, 5s, 10s, 30s and 60s. Press the “◀” or “▶” button to select an appropriate number of seconds, then press the Menu button for confirmation and hold down the Menu button to return

to the previous menu.

## 13.5 System setting

The system setting menu bar includes language, system format, default settings, screen brightness, system time, automatic shutdown, automatic screen off, volume, onboard mode, cyclic video recording, onboard audio recording, segmented video recording, button tone, indicator, infrared switching, motion detection, exposure compensation, ID No., and system information. Select the icon of the system setting menu, press the “◀” or “▶” button to select the option to be set, and then press the Menu button to enter.

### 13.5.1 Language

In the language selection menu, users can select a language as the system language. The reference interface of language selection is as follow:



### 13.5.2 System format

The system format, also known as the television broadcasting format, can be either NTSC or PAL. When the device outputs as television, the right option should be selected based on the format of the television set.

### 13.5.3 Default settings

Users can use this function to reset the settings of the device.

### 13.5.4 Screen brightness

When this function is to be used, the brightness of the screen can be adjusted. Three screen brightness levels are available: high, medium and low. Press the “◀” or “▶” button to select an appropriate option, then press the Menu button for confirmation and hold down the Menu button to return to the previous menu.

### 13.5.5 System time

The reference system time setting screen is as shown below:

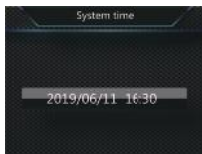

In this screen, hold down “≡” to return to the previous menu, and press the “◀” or “▶” button to adjust the value of the corresponding position. Press “≡” to select the year, month, date, hour and minute; after reaching the minute option through consecutive pressing “≡”, press “≡” again to confirm the change and return to the previous menu.

---

### 13.5.6 Automatic shutdown

If no operation to the device within the set time, the system will shut down. The reference interface is as follow:



---

### 13.5.7 Automatic screen off

Four options of automatic screen off are available: off, 1min, 3min, and 5min. If no operation is done to the device within the given time, the screen will black out. If “off” is selected, the screen will remain illuminated.

---

### 13.5.8 Volume

When this function is to be used, the volume of the device can be adjusted.

The volume can be selected from the 17 integers of 0~16. Press the “◀” or “▶” button to select an appropriate volume, and then press the Menu button for confirmation.

### 13.5.9 Cyclic video recording

In the video recording setting menu, select the “Cyclic Video Recording” menu, and then press the Menu button to enter the cyclic video recording menu. Two options are available: off and on. Press the “◀” or “▶” button for selection, then press the Menu button for confirmation and hold down the Menu button to return to the previous menu.

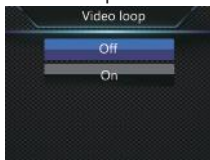

### 13.5.10 Onboard audio recording

Users can use this function to select if the interior sound is to be recorded.

### 13.5.11 Segmented video recording

Five options are available: 5min, 10min, 15min, 20min, and

30min. During video recording, a segmented video file will be saved for the set time, and the recording of the next video file will begin seamlessly. The reference segmented video recording screen is as shown below:



### 13.5.12 Keypad tone

With this function, every keypad operation has a prompt tone.

### 13.5.13 Indicator

Users can use this function to turn on or off the status indicator as necessary.

---

### 13.5.14 Infrared switching

In the system setting menu, press the “◀” or “▶” button to select the “Infrared” menu, and then press the Menu button to enter the infrared switching menu. Two options are available: manual and automatic. Finish the selection, then press the Menu button, and hold down the Menu button to return to the previous menu.

---

### 13.5.15 Motion detection

When the device is in the standby mode, the video recording function will start automatically when an object enters the shooting range; when the object leaves the shooting range, this function will be ended, and the video file saved. Two options are available: off and on.

---

### 13.5.16 Exposure compensation

Exposure compensation is an exposure control mode that makes photos brighter or darker. Users can adjust photo brightness based on the idea to create unique visual effects. Users can set exposure compensation from 13 values within -2.0~+2.0. Press the “◀” or “▶” button to select an appro-

priate value, and then press the Menu button for confirmation.

---

### 13.5.17 ID No.

The reference ID No. setting screen is as shown below:

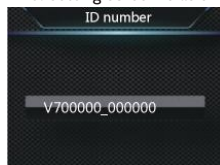

In this screen, hold down the Menu button to return to the previous menu, press the “◀” or “▶” button to adjust the value of the corresponding position, and press the Menu button to select the corresponding digit. When the Menu button is pressed consecutively to the last digit, press the Menu button again to confirm the change and return to the previous menu.

---

### 13.5.18 System info

The system info menu includes gross storage capacity, usable space, usable video recording time, usable audio recording time, battery power and version number.

Gross storage capacity: View the memory information.

Usable space: View the remaining space information.

Usable video recording time: View the video recording time for the current video recording resolution.

Usable audio recording time: View the audio recording time for the current audio recording type.

Battery power: View the current battery power information.

Version number: View the firmware version information.

## 14 Mounting of Shoulder Clip

---

To mount the jacket, insert the R position of the jacket insert into the slot of the device, and push the jacket slowly until the insert reaches the bottom of the slot.

As shown below:

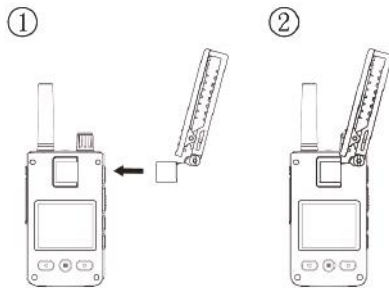

---

### 14.2 Dismounting of clip

To remove the jacket, hold the jacket and the device while supporting the insert, and pull it gently.



## 15 Wearing Shoulder Clip

---

(1) Press the hand clip to open the clip, and then clamp toward the shoulder strap so that the hook catches the root of the shoulder strap.



(2) Unleash the hand clamp to clip the shoulder clamp and adjust the device to an appropriate position.



## 16 Frequently Asked Questions (FAQ)

---

This section has listed all the frequently asked questions to help you address the simple issues during use of the voice/video recorder. If such issues persist, please consult our dealers or visit our official website: [www.philips.com/support](http://www.philips.com/support)

---

### 16.1 Failure to start the recorder

The battery is empty, please recharge promptly.

---

### 16.2 Incorrect time/date

The time of the device is inaccurate. Please reset the time on the menu.

---

### 16.3 Unclear image

Unclean lens has caused it. Please use clean cloth to clean it.

---

### 16.4 Failure to record audio/video

The memory of the device is full, and the cyclic video record-

ing is not started. Please delete some of the files or transfer such files to external storage devices.

---

### 16.5 Recorder is unable to play audio or video files

Please recharge the battery as it has run out of power.

---

### 16.6 Failure to record audio/video

If the device fails, such as starting failure, blackout or operation failure, the common treatment is to reset it. Turn off the interphone before resetting. Open the rubber plug of the headphone/USB/micro SD card, and press the small hole above the midpoint between the USB port and the micro SD card with the tip of a sign pen, etc.

## 17 Technical Parameter

---

### 17.1 Memory

External Memory Space

Reference audio recording time (16GB): ca. 86 hours

Type of Internal Memory: C10 TF card

Mobile memory (PC): Yes

---

### 17.2 Size & weight

Width\* Height\*Depth: 58×100×26 (mm)

Weight (including battery): 203g (excluding shoulder clip)

---

### 17.3 System requirements

Operating System: Windows 7/8/10/Vista/XP/2000, Mac OS X, Linux

Port: USB

---

### 17.4 System requirements

HQ: bit rate 1536kbps; WAV format

SLP: bit rate 384kbps; WAV format

### 17.5 Memory

Temperature: -30 °C ~ 55 °C

Air Humidity: 10%-90%, uncondensed



**Warranty card**

**质保书**

1

year warranty

**一年质保**

Type: VTR8300

Serial nr:

Date of purchase

购买日期

Dealer's name, address and signature

销售商名称、地址及签字

**[www.philips.com/welcome](http://www.philips.com/welcome)**

This document is printed on chlorine free produced paper  
Data subject to change without notice

This product was brought to the market by Speech Processing Solutions GmbH or one of its affiliates, further referred to in this document as SPS, which is the manufacturer of the product. SPS is the warrantor in relation to the product with which this booklet was packaged.

For China only  
只限中国地区

Printed in China







